

Modifying Main Well Casting to Receive Conical Accelerator Pump Check Valve

These conical check valves are an upgrade to the ball checks that were original equipment. They stayed seated better under hard use.

Conical Check Valve Modification For Accelerator Pump Circuit – Inline Autolite

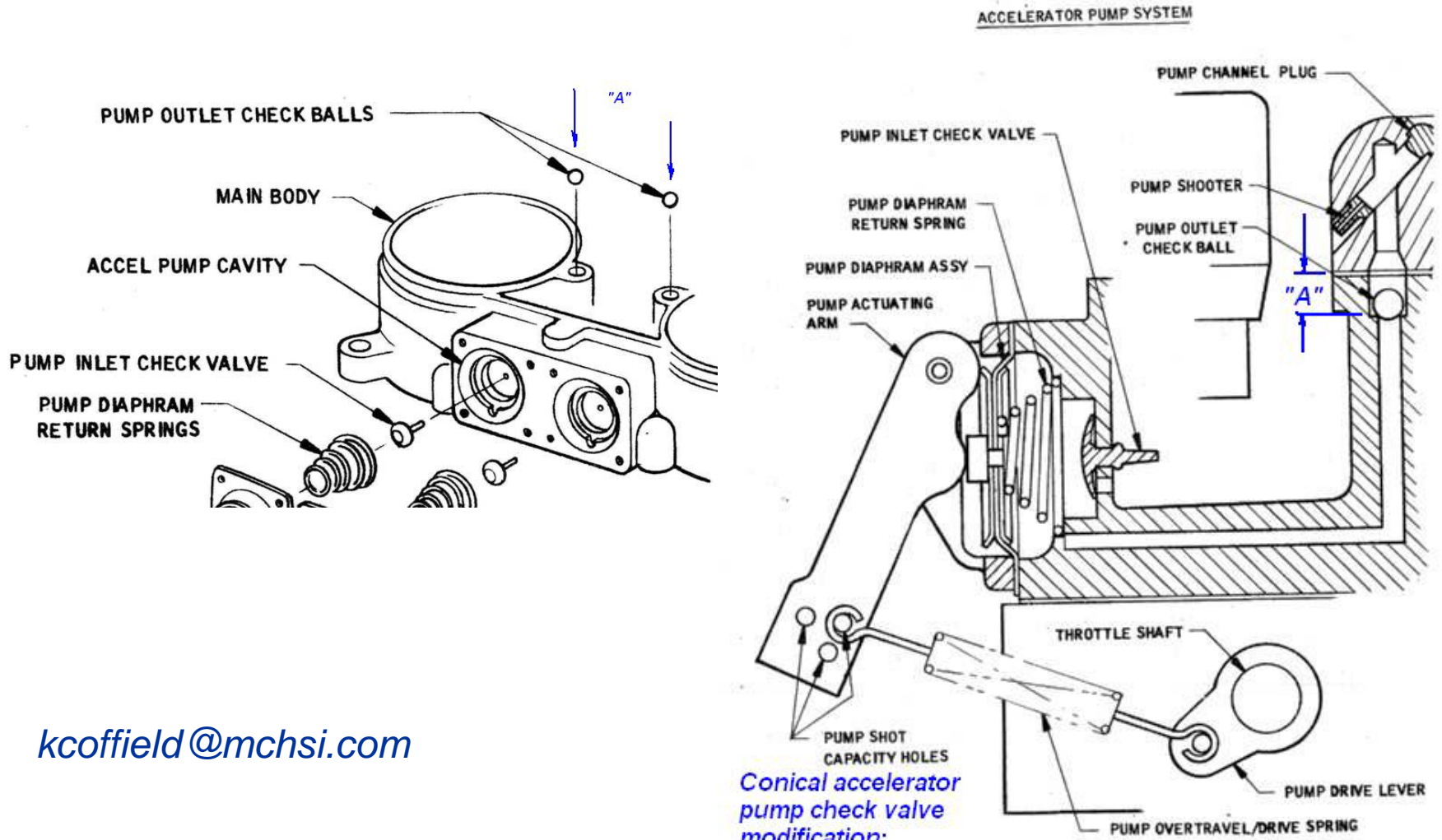

kcoffield@mchsi.com

Conical accelerator pump check valve modification:

- For dimension "A": Drill .600" deep using a .217"/.225" Drill



I recommend using an end mill to make the mod described on the previous slide because it cuts crisp flat bottom hole and a good edge to coin the check valve seat.

*Set of 4 conical accelerator
pump check valves included
with installation instructions.*



kcoffield@mchsi.com

